

# B-ware™ Smart Hive Monitor



The primary element of the **B-ware™ Beehive Monitoring System** is the **B-ware™ Smart Hive Monitor**. The Smart Hive Monitor measures and stores weight and temperature readings every 15 minutes. These readings are very precise and can measure even very slight changes in beehive weight. Hive monitors can be read either with a handheld device such as a smartphone or remotely and automatically using a B-ware™ Data Collector.

- In the simplest implementation, individual monitors are read one-by-one with the **B-ware™ Mobile App** loaded on your Android or iOS handheld device. A Bluetooth connection is easily established and the data is uploaded to the phone - and from there to the Internet if the smartphone is in cell tower range.
- Alternatively, each Smart Hive Monitor can communicate directly with a **B-ware™ Data Collector** which automates the daily reading of the stored weight and temperature measurements in the monitor. This logged data is passed to the Data Collector twice a day. Alarms issued by the monitor are passed immediately to the Data Collector. From the Collector the data is read and sent to the Internet either directly using a smartphone, via Wi-Fi, via a cellular or a satellite connection. Up to 100 Hive Monitors can be accessed by one Data Collector within a radius of 150ft (30m).

**Technical Specifications:**

Model	
HM-20	
<b>Operating Temperature Range</b>	15F to 140F (-10C to 60C)*
<b>Accuracy Class</b>	C3MR (in accordance with OIML-R60)
<b>Minimum Verification Interval (v<sub>min</sub>)</b>	3.5 oz. (100g)
<b>Max. Weight</b>	550 lbs. (250kg)
<b>Battery Life</b>	min. 2 years

\* The equipment will work normally within its temperature operating range. At extreme temperatures outside of this range, the equipment will purposefully shut down to avoid excess energy usage and will start operating again when within operating temperature range.

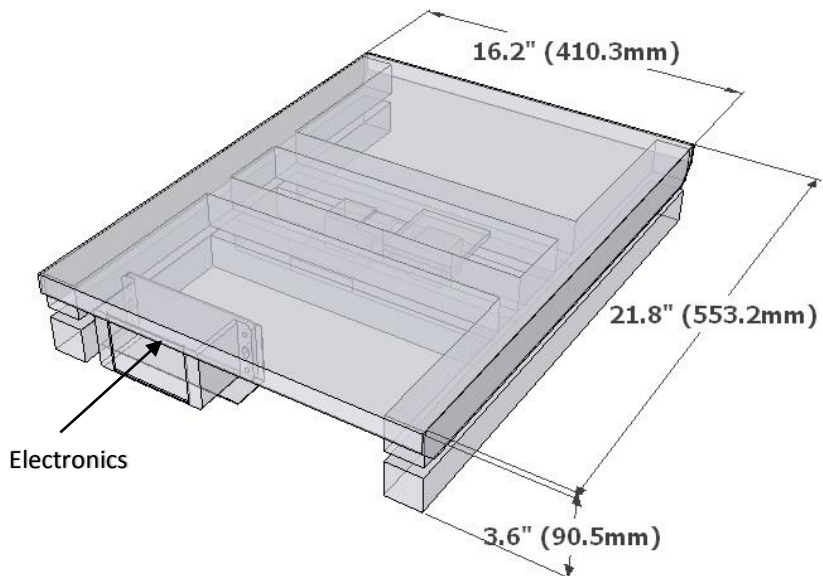

**Beehive Monitoring System**

Solutionbee delivers the highest quality beehive monitoring system in the industry with the most value. Reliable, technical and user-friendly solutions are Solutionbee’s specialty.

Solutionbee’s dedicated customer technical support assists distributors and end-users to set-up and maintain the hive monitoring equipment.



**SOLUTIONBEE**  
REMOTE READING SOLUTIONS

Solutionbee LLC  
8112 Glenbrittle Way, Suite 3000  
Raleigh, NC 27615 USA  
+1 919 607 3407  
sales@solutionbee.com